

# **User Manual**

## **Standalone Lithium-Iron Phosphate Battery Module**

**Version: 1.1**

# Table of Contents

1.	Safety Precautions.....	1
	1.1 Before Connecting .....	2
	1.2 In Use .....	2
2.	Introduction .....	3
	2.1 Features .....	3
	2.2 Package Contents.....	4
	2.3 Specifications .....	5
	2.4 Product Indicator & Setting .....	6
3.	Installation.....	10
	3.1 Installation Environment .....	10
	3.2 Mounting the Modules .....	11
	3.3 Wiring Configuration .....	15
	3.4 Wiring Diagrams of Diverse Applications.....	20
4.	Start-Up/Shut-Off the Battery Module .....	24
	4.1 Start up the battery module .....	24
	4.2 Shut-off the battery module.....	24
5.	Trouble Shooting.....	25

Thank you for purchasing LIO II-4810 Lithium battery module. Please read this manual before you install the battery. Follow the instruction carefully during the installation process.

## 1. Safety Precautions



### Reminder

- 1). It is very important and necessary to read the user manual carefully before installing or using the battery. Failure to do so or to follow any of the instructions or warnings in this document can result in electrical shock, serious injury, or death, or can damage the battery, potentially rendering it inoperable.
- 2) If the battery is stored for a long time, it is required to charge them every six months, and the SOC should be no less than 90%;
- 3) Battery needs to be recharged within 12 hours, after fully discharged;
- 4) Do not expose cable outside;
- 5) All the battery terminals must be disconnected for maintenance;
- 6) Do not use cleaning solvents to clean the battery;
- 7) Do not expose battery to flammable or harsh chemicals or vapors;
- 8) Do not paint any part of the battery, include any internal or external components;
- 9) Do not connect the battery with PV solar wiring directly;
- 10) The warranty claims are excluded for direct or indirect damage due to the items above.
- 11) Any foreign object is prohibited to insert into any part of the battery.

## **Warning**

### **1.1 Before Connecting**

- 1) After unpacking, please check the product and packing list first, if the product is damaged or missing parts, please contact the local retailer;
- 2) Before installation, be sure to cut off the grid power and make sure the battery is in the turned-off mode.
- 2) Wiring must be correct. Do NOT misconnect the positive and negative cables, and ensure no short circuit with the external device.
- 4) It is prohibited to connect the battery and AC power directly.
- 5) The embedded BMS in the battery is designed for 48VDC, please DO NOT connect the battery in series.
- 6) Please ensure the electrical parameters of the battery system are compatible with related equipment.
- 7) Keep the battery away from water and fire.

### **1.2 In Use**

- 1) If the battery system needs to be moved or repaired, the power must be cut off and the battery is completely shutdown
- 2) It is prohibited to connect the battery with a different type of battery
- 3) It is prohibited to put the batteries working with faulty or incompatible inverter;
- 4) It is prohibited to disassemble the battery (QC tab removed or damaged);
- 5) In case of fire, only dry powder fire extinguisher can be used, liquid fire extinguishers are prohibited.
- 6) Please do not open, repair, or disassembly the battery except staff authorized. We do not undertake any consequences or related responsibility which because of violation of safety operation or violating of design, production, and equipment safety standards.

## 2. Introduction

LIO II-4810 Lithium iron phosphate battery modules are new energy storage products. It is designed to integrate with reliable inverter modules.

It is built-in smart BMS battery management system, which can manage and monitor cells' information including voltage, temperature, current, etc.

Moreover, BMS can balance cells charging and discharging to extend cycle life. Battery modules can be used alone or in parallel, to expand capacity for different requirements.

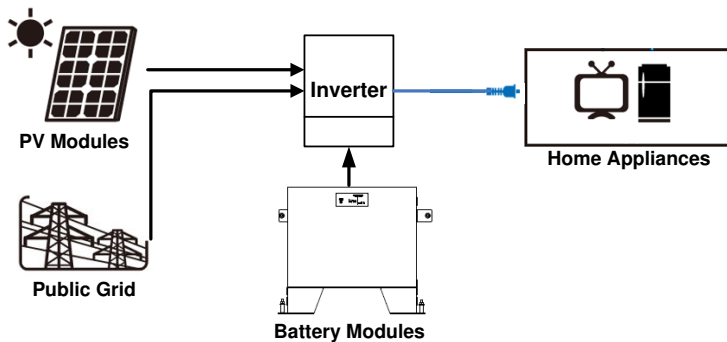

### 2.1 Features

- Non-Toxic, non-polluting, and friendly to the environment.
- LiFeO<sub>4</sub> cell material, safety performance, and long cycle life.
- Smart BMS protection functions: over-discharge, high temperature, over-charge, over-current.
- Flexible configuration, multiple battery modules can be easily stacked and added for energy expansion.
- Working temperature range is from 0°C to 50°C with excellent discharge performance and cycle life.

## 2.2 Package Contents

The packaging is recyclable, save it for reuse or dispose of it properly.

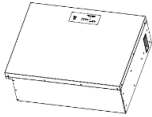

Battery Module



Manual

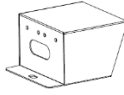

Stand Feet (x2)

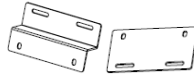

Fixing Plates for  
Stand feet  
(Left x1, Right x1)

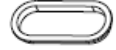

SNAP bushing  
(x2)



L-type Brackets (x2)



Fixing Plates (x2)

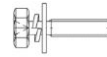

Screws (x20)

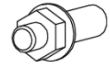

Expansion Bolt  
M10 (x4)



External Battery connectors  
(BAT+ x2, BAT- x2)



RJ45 cable



RJ11 cable



RJ11 Jumper

PDU module can be purchased separately. Following contents will be included in its separately package:

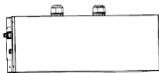

PDU Module



Cable Gland (x2)

## 2.3 Specifications

Model	LIO II-4810
Capacity (Wh)	5120 Wh
<b>PARAMETERS</b>	
Nominal Voltage	51.2 VDC
Typical Capacity(Ah)	100 Ah
Full Charge Voltage (FC)	56 V ± 0.1 V
Full Discharge Voltage (FD)	42 V
Max. Continuous Discharge Current	150 A
Max. Peak Discharge Current	192 A at 1min
Protection	BMS, Breaker
Max. Charge Voltage	52.5 V ± 0.1 V
Max. Charge Current	100 A
Standard Charge Method	0.2C CC (Constant Current) charge to FC, CV (Constant Voltage) charge till charge current decline to <0.05C
Inner Resistance	≤20mΩ
Storage Temperature	-20°C ~ 60 °C 20°C±5°C is the recommended storage temperature
Dimension (D x W x H) mm	185 x 540 x 420
Dimension with stand feet (D x W x H) mm	185 x 540 x 530
Net Weight (kg)	48
Operation Temperature	Charge : 0°C ~ 50 °C Discharge : 0°C ~ 50 °C
Communication	RS485 (RJ45), extension port (RJ11)
Certifications	UN38.3, IEC 62619

## 2.4 Product Indicator & Setting

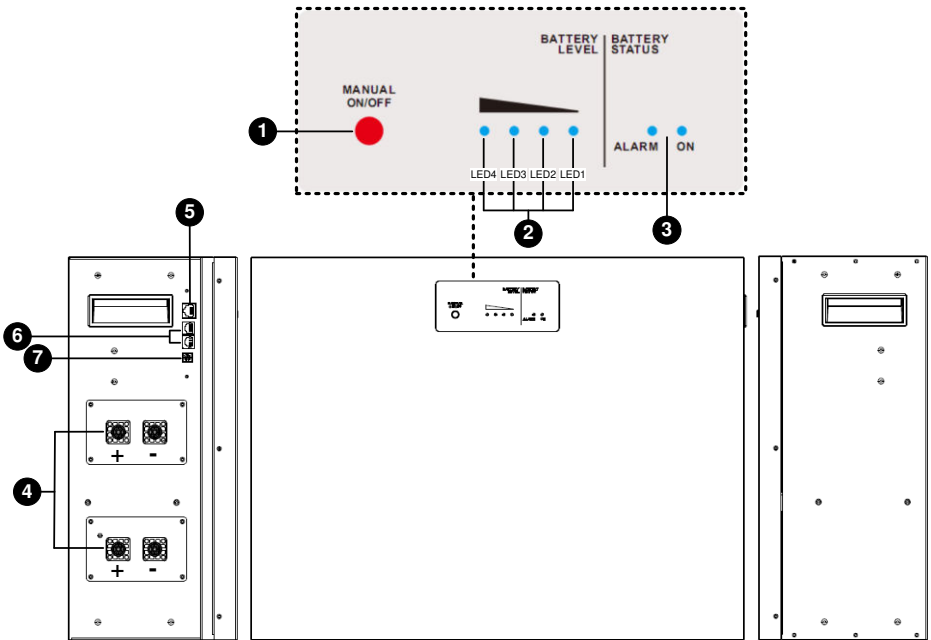

**1 Manual power on/off button** - to wake up or shut down the battery module.

- If battery module is off, press and hold the button over 5 seconds to turn on the module.
- If battery module is working, press and hold the button for approximately 5 seconds to shut down the module.

**2 Battery Level LEDs** - Indicates battery level. Please refer to the LED indicator table for the details.

**3 Battery Status LEDs** - Indicates battery module status. Please refer to the LED indicator table for the details.



## LED Indicator:

Battery Status		Battery Status LEDs			Battery Level LEDs			
Status	SOC	ON	ALARM	LED1	LED2	LED3	LED4	
Normal Mode	Charging	0%~25%	ON	OFF	Flash	OFF	OFF	OFF
		26%~50%	ON	OFF	ON	Flash	OFF	OFF
		51%~75%	ON	OFF	ON	ON	Flash	OFF
		76%~100%	ON	OFF	ON	ON	ON	Flash
	Discharging	0%~25%	ON	OFF	ON	OFF	OFF	OFF
		26%~50%	ON	OFF	ON	ON	OFF	OFF
		51%~75%	ON	OFF	ON	ON	ON	OFF
		76%~100%	ON	OFF	ON	ON	ON	ON
Alarm mode	Warning	-	OFF	Flash	-			
	Fault	-	OFF	ON	-			
Power Off		-	OFF	OFF	OFF	OFF	OFF	

### 4 External Battery Connector

There are two sets of battery connectors in parallel. Positive terminals are marked in "BAT+" and Negative terminals are marked in "BAT-".

### 5 RS485 Port (BMS Communication Port)

- Connector type: RJ45
- Function: communication between battery module and inverter module.

- Pin Definition:

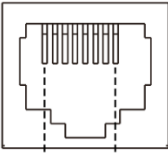
	<b>PIN</b>	<b>Definition</b>
	1	RS485B
	2	RS485A
	3	NC2
	4	RS485B
	5	RS485A
	6	PresentA
	7	PresentB
8	NC1	

## 6 Extension Port

- Connector type: RJ11
- Function: BMS signal transmission for battery module and for battery capacity extension in parallel.
- Pin Definition

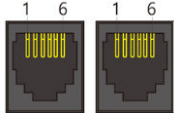
	<b>PIN</b>	<b>Definition</b>
	1	CANH
	2	CANL
	3	PresentA
	4	PresentB
	5	NC
6	NC	

## 7 ID Switch

- ID Switch indicates the unique ID code for each battery module. It's required to assign a unique ID to each battery module for normal operation.
- We can set up the ID code for each battery module by rotating the PIN number on the ID switch. From number 0 to 9, the number can be random; no particular order.
- If more than one battery module in the parallel system, the battery pack connected to the inverter module is the Master battery and the ID code should be set as 0. The ID code of the remaining battery module MUST be unique. Do not set the same number for 2 battery modules in the parallel system.
- Maximum 10 battery modules can be operated in parallel.

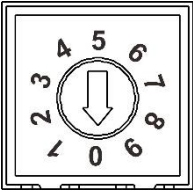
	<b>PIN</b>	<b>Definition</b>
	0	0x0F
	1	0x0E
	2	0x0D
	3	0x0C
	4	0x0B
	5	0x0A
	6	0x09
	7	0x08
	8	0x07
9	0x06	

## 3. Installation

### 3.1 Installation Environment

Make sure that the installation environment meets the following conditions:

- The area is completely waterproof.
- The floor is flat and level.
- There are no flammable or explosive materials nearby.
- The ambient temperature is within the range of 0~50°C.
- The temperature and humidity are maintained at a constant level.
- There is minimal dust and dirt in the area.



#### **Caution:**

If the ambient temperature is out of the operating range, the battery module will stop operate to protect itself. The optimal temperature range for the battery module to operate is 0°C to 50°C. Frequent exposure to harsh temperatures may deteriorate the performance and shorten the life cycle of the battery module.

### 3.2 Mounting the Modules

**Step 1:** Clip two SNAP bushings into the stand feet. Then, fix two fixing plates on the stand feet (both sides) with eight screws. Finally, fix two L-type brackets on the battery module (both sides) with four screws.

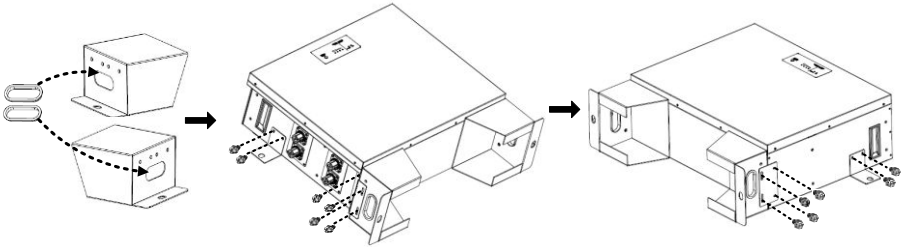

**Step 2:** Install one battery module by following below steps.

- (a) Use a  $\varnothing 13\text{mm}$  drill to drill holes about 60mm deep according to the distance indicated on the below chart. Drill two holes on the floor first, then drill two holes on the wall. If there is one more battery module to be stacked up, drill two holes at a vertical distance of 420mm.

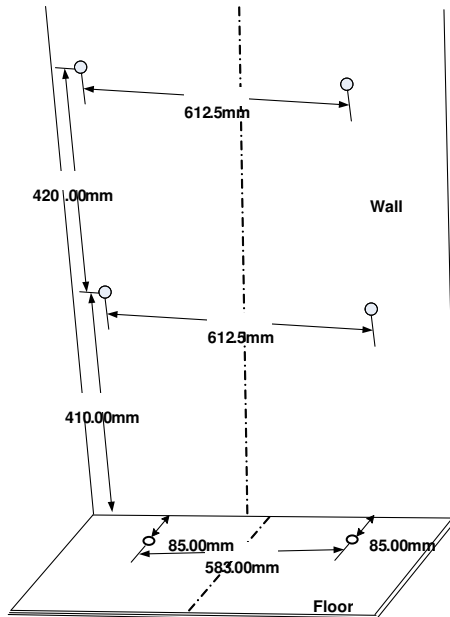

- (b) Push four expansion bolts into the  $\text{\O}13\text{mm}$  holes drilled on the previous step.

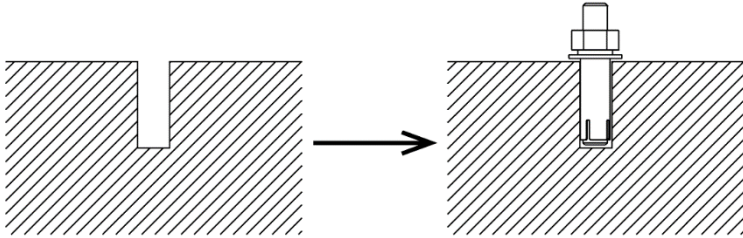

- (c) Remove nut, spring washer and flat washer.

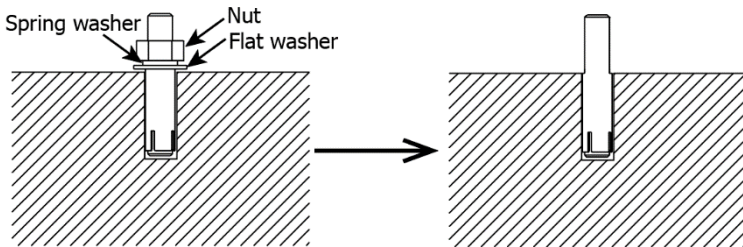

- (d) Take assembled battery module (in step 1) and put on the ground. Align the hole on fixing plate with the two expansion bolts on the ground. Align the hole on L-type bracket with two expansion bolts on the wall. Pass through the remaining bolt in the floor and wall. Then, screw back the nut, spring washer, and flat washer

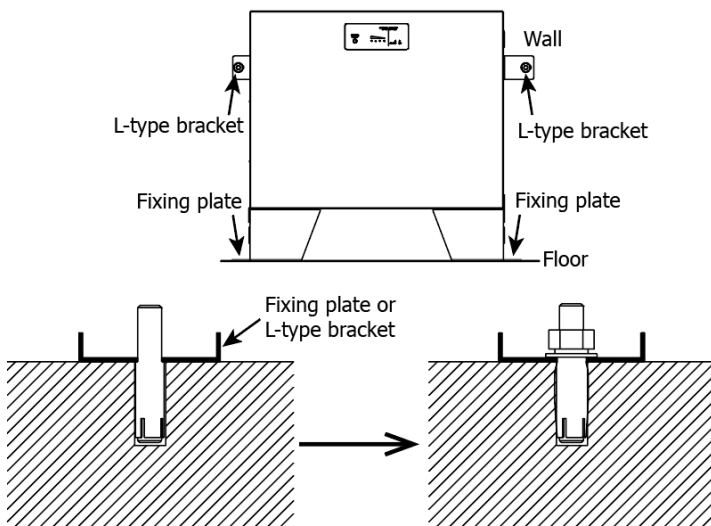

### Step 3 (If more than one battery module is connected):

For a single battery module connection, please skip this step! If more than one battery module is connected, please follow the instructions below:

- (a) Put the additional battery module on the top of battery module installed on the ground. Make sure they are aligned well.
- (b) Install one fixing plate to fix two battery modules with four screws as following the picture shown.

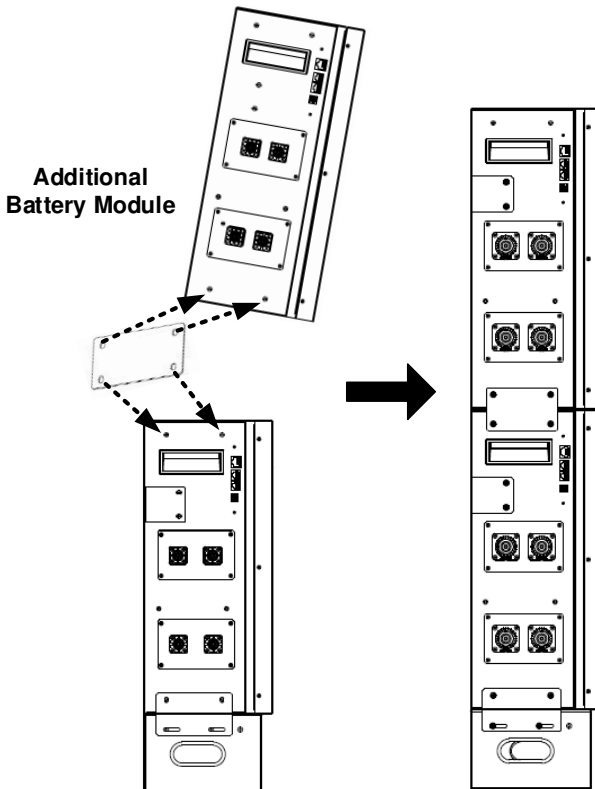

- (c) Follow the same procedure as step (b) to fix the other side.
- (d) Refer to **Step 2**, fix the top battery module on the wall with two expansion bolts.

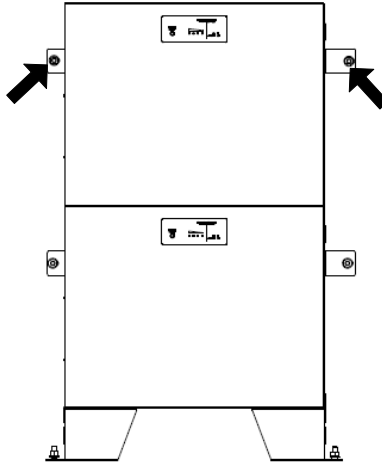

- (e) If there are more battery modules installed, repeat steps (a) to (d).

**Step 4 (If an optional PDU module is required in the system):** Stack the PDU module on the top of all battery modules. Install two fixing plates (supplied in PDU module package) on both sides of the modules with eight screws.



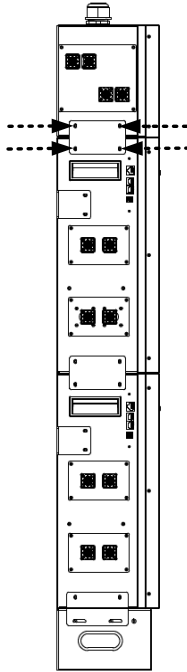

### 3.3 Wiring Configuration

**Step 1:** Insert the supplied RJ11 jumper into one of the extension port on the top of the battery module.

\*It's required to connect to the battery module for normal operation.

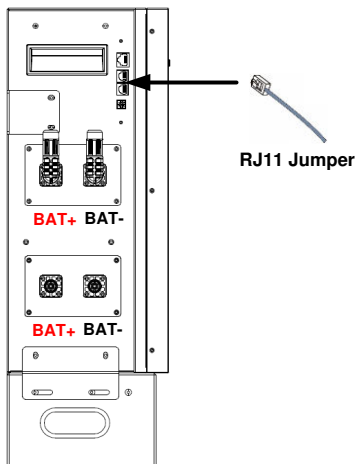

**Step 2 (If multiple battery modules are in parallel):** Insert RJ11 cable to connect the extension port of the master battery module\*. The other end connects to the extension port of the #2 battery module. If there are more battery modules are connected in the system, repeat this step to connect more battery modules.

**Caution:**The battery module connected to the power module is the Master battery and the ID code should be set as 0.

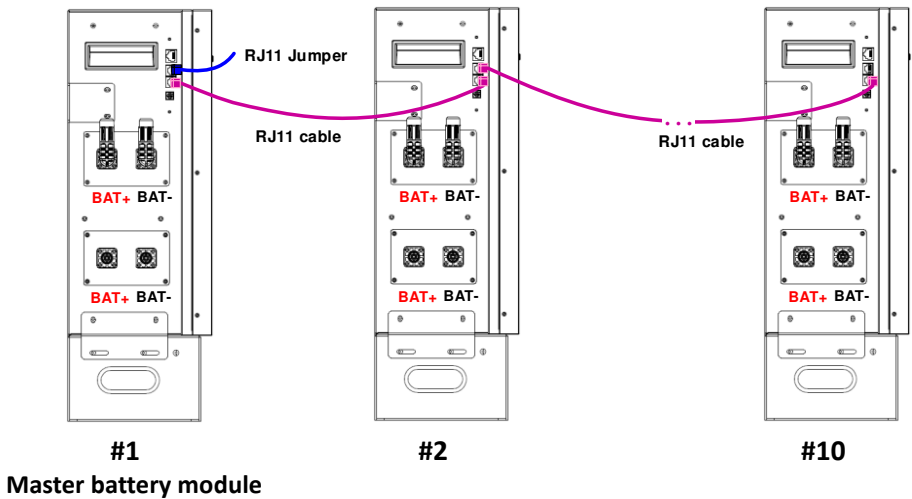

**Step 3:** Insert the supplied RJ45 cable into the RJ45 communication port on the master battery module. The other end connects to BMS communication port on the inverter module.

**Caution:** "BAT" and "INV" are marked on the RJ45 cable. Make sure connect the battery module and inverter module with correct end.

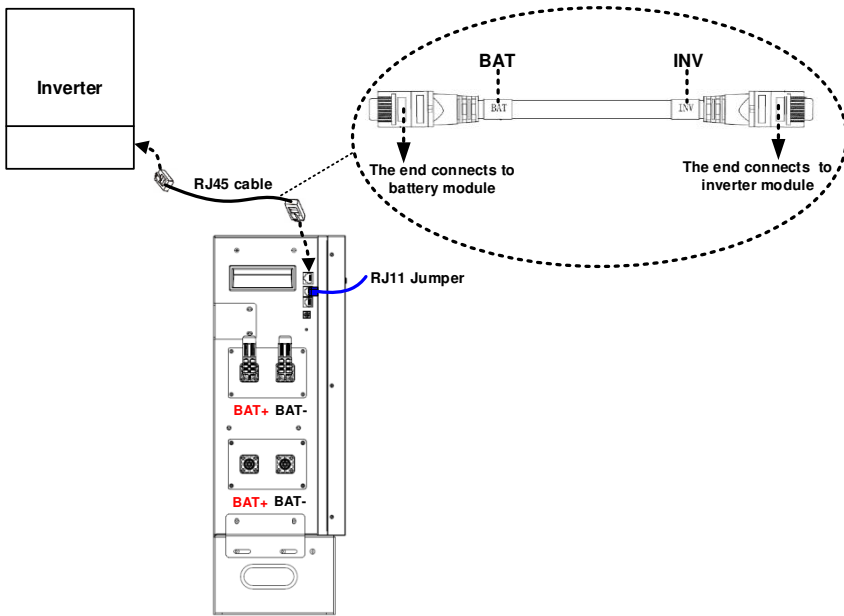

**Master battery module**

**Caution:** CAUTION: If more than one battery modules are connected for capacity extension, the battery module connected to inverter module directly will be defined as "Master battery module". Be sure to set ID number for Master battery module as "0".

**Step 4:** Please follow below steps to prepare battery cable with supplied external battery connectors. The cable length should be prepared based on the real distance between battery module and inverter module.

The recommended cable size is listed as below:

Wire Size	Cable mm <sup>2</sup>
1*4AWG	25

(a) Loosen and disassemble the plug of the supplied battery connector.

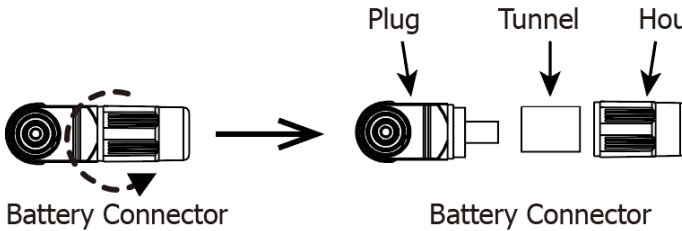

(b) Insert the battery cable through the tunnel and housing, and strip battery cable  $11.5 \pm 0.2$ mm.

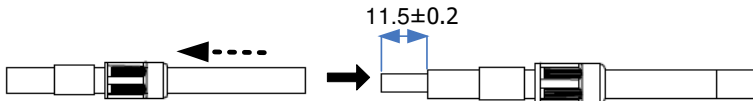

(c) Crimp the cable and the plug with a proper crimping tool (ex. hydraulic clamp) together into a hexagon shape as shown in below chart. Then, move the housing toward plug and tighten them.

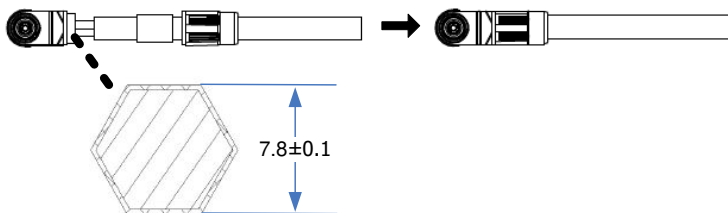

- (d) Use battery cable to connect the battery module and inverter module. Make sure the polarity of battery module are correctly connected.

**RED connector to the positive terminal (+)**

**BLACK connector to the negative terminal (-)**

If more than one battery modules are connected, use battery cable to connect master battery module and remaining battery module one by one.

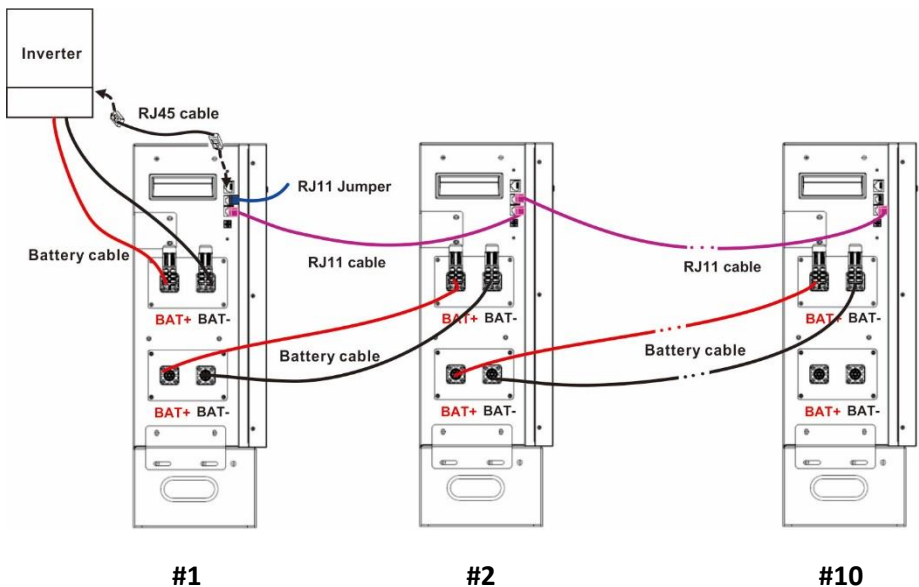

**Master battery module**

- (e) After connecting all cables, the battery modules are ready for DC output.

### 3.4 Wiring Diagrams of Diverse Applications

(1) Single battery module connection with a max 150A current wiring:

(suitable for  $\leq 6\text{KW}$  Inverter)

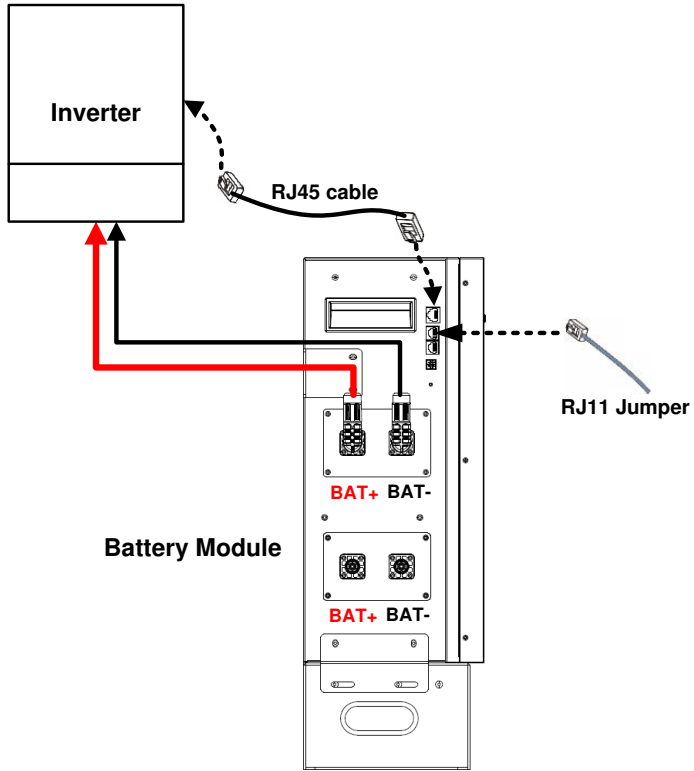

(2) Two-battery module connection for a longer backup time with a max 150A current wiring:

(suitable for  $\leq 6\text{KW}$  Inverter)

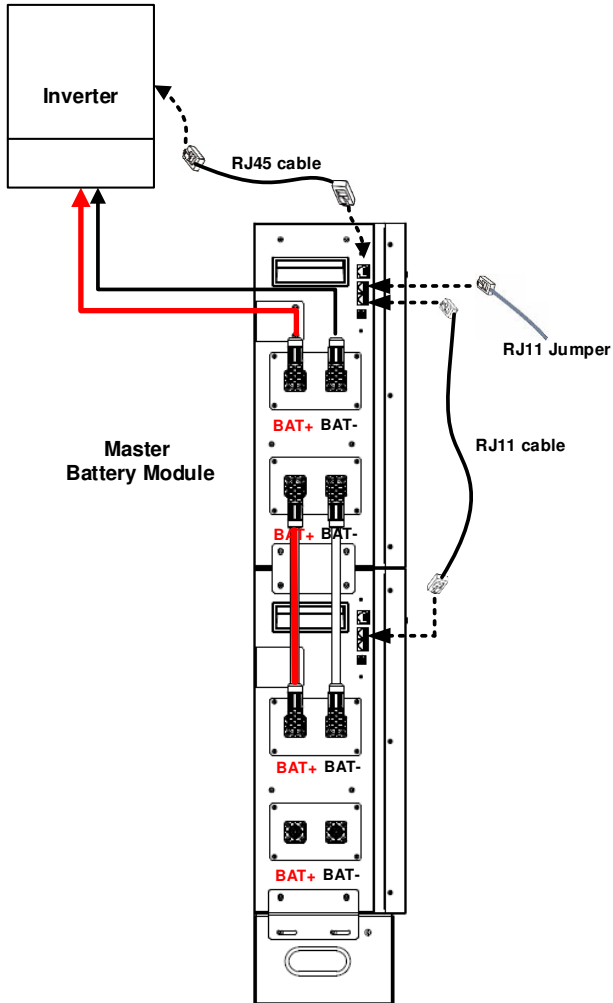

- (3) Two-battery module connection for a larger-capacity Inverter:  
(suitable for >6KW Inverter)

**\*PDU module is required for combining battery pack current!**

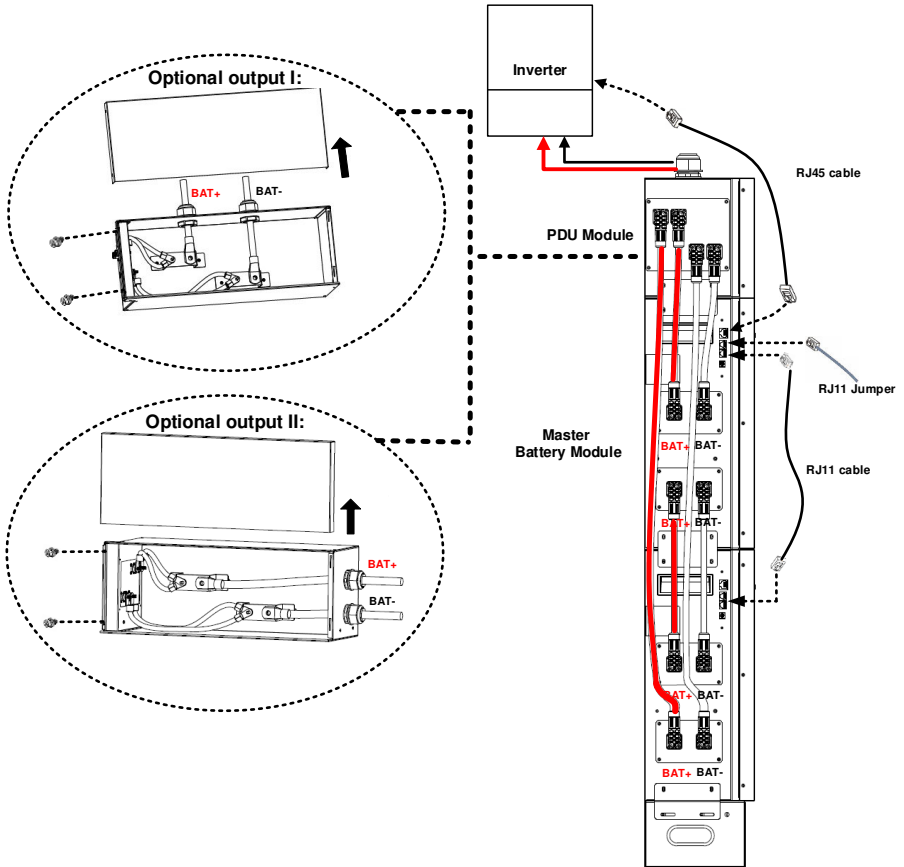



(4) Multiple battery modules in parallel for large-capacity inverter with a longer backup time:

(suitable for >6KW Inverter):

**\*PDU module is required for combining battery pack current!**

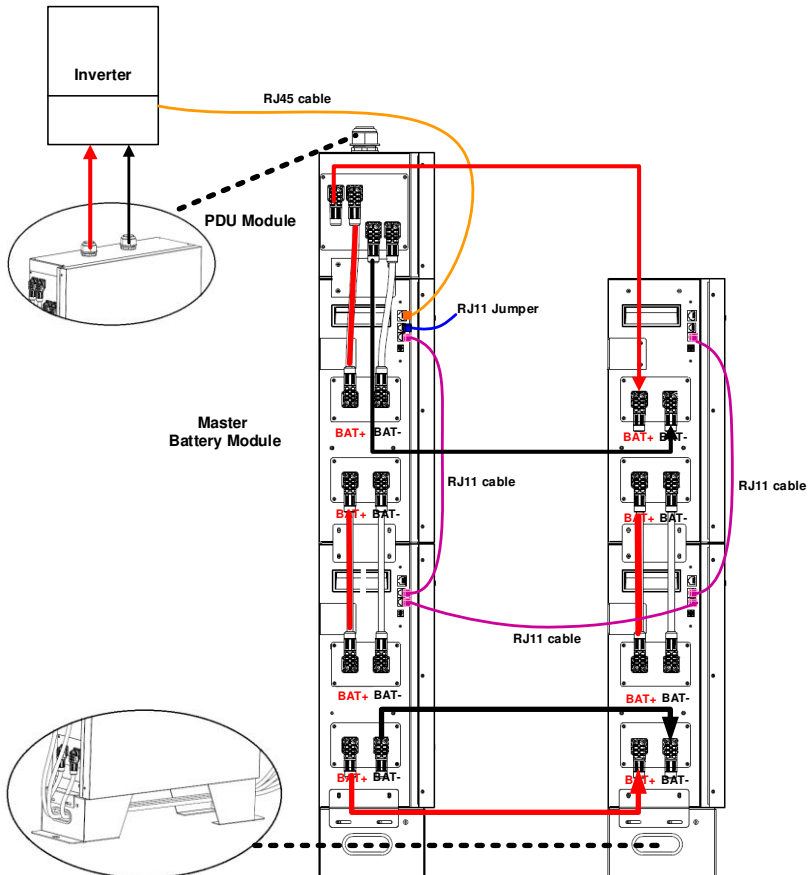

## **4. Start-Up/Shut-Off the Battery Module**

### **4.1 Start up the battery module**

- (a) When battery module is in the shutdown mode, press manual ON/OFF button for over 5 seconds.
- (b) Or, simply turn on the the inverter module which is connected to a battery module already. The battery module will be automatically turned on.

\*If the manual button cannot be approached, just simply turn on the Inverter module. The battery module will be automatically turned on.

### **4.2 Shut-off the battery module**

When battery module is in the operating mode, press manual ON/OFF button for 5 seconds.

## 5. Trouble Shooting

Use the table below to solve minor installation and operation problems.

Situation	Fault Event Description	Solution
Battery pack no output	RJ11 jumper is missing.	Re-check if the RJ11 jumper is connected well.
Battery cannot discharge	Same ID code set in multiple battery packs.	Re-set each battery with different ID codes.
	Under-voltage protection.	Charge battery.
	Protection against over-temperature or under-temperature (cell temperature is lower than -20°C or higher than 80°C).	Regulate cell temperature in the range of -20°C to 60°C for discharge.
	Protection against over current.	Remove some non-critical load and charge battery.
	Battery output is short circuited.	Relieve short circuit and charge battery.
	System failure detected.	Shut down system and call maintenance service.
	In parallel battery packs, CAN communication lost and "parallel imbalance" occur on slave battery.	Ensure communication wires are all correctly connected well.
	Battery cannot charge	Protection against over current.
Protection against over-temperature or under-temperature (cell temperature is lower than 0°C or higher than 60°C).		Regulate cell temperature in the range of 0°C to 50°C for charge.
System failure detected.		Shut down system and call maintenance service.
Communication failure is detected	Communication cable is not connected well.	Check if communication cable is firmly connected.
	Communication ID switch conflict.	Check the parallel batteries ID switch setting and correct them.
	System failure detected.	Shut down system and call maintenance service.